

SPECIFICATIONS	
CONTACT CARRIER MATERIAL	PVC
MOLDED HEAD MATERIAL/COLOR	PVC/BLACK
CONTACT MATERIAL/PLATING	BRASS or COPPER/GOLD
COUPLING NUT MATERIAL/PLATING	BRASS/NICKEL
RATED CURRENT [A]	40 A COMBINED, 21 A DROP
RATED VOLTAGE [V]	600 V
TEMPERATURE RANGE	-40°C to +90°C (-40°F to +194°F)
PROTECTION CLASS	MEETS NEMA 1,3,4,6P AND IEC IP67
APPROVALS AND CERTIFICATIONS	UL 2237, UL 2238

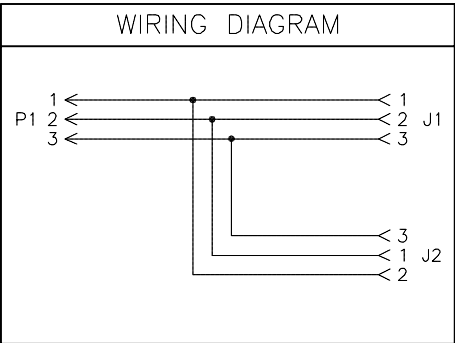
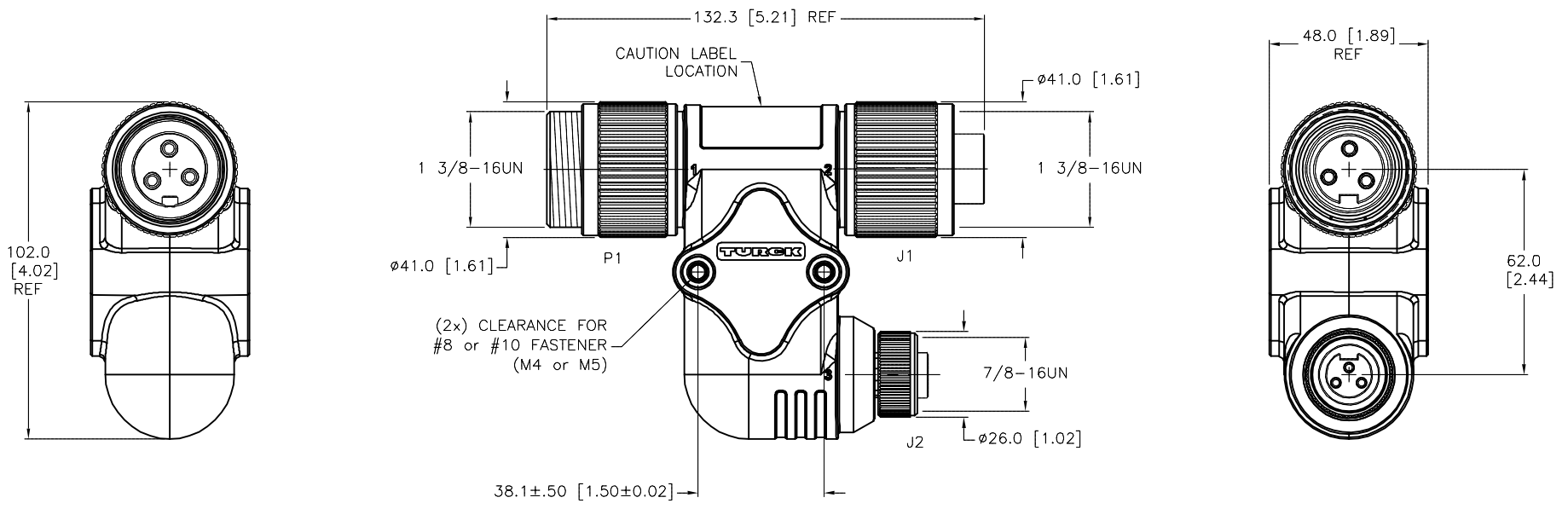

**CAUTION:**  
 RISK OF ELECTRICAL SHOCK  
 DO NOT DISCONNECT UNDER LOAD

SOURCE DRAWING - FOR REFERENCE ONLY

RELATED DOCUMENTS 1. 2. 3. 4.	3RD ANGLE PROJECTION 	THIS DRAWING IS CONFIDENTIAL AND THE PROPERTY OF TURCK INC. USE OF THIS DOCUMENT WITHOUT WRITTEN PERMISSION IS PROHIBITED.		3000 CAMPUS DRIVE MINNEAPOLIS, MN 55441 1-800-544-7769 (763) 553-7300 (763) 553-0708 fax www.turck.us	
		MATERIAL  SEE SPECIFICATIONS	DRFT RWC APVD	DATE 07/17/09 SCALE 1=2.0	DESCRIPTION SH-GSDM/GKDM/RKM 34
FINISH  SEE SPECIFICATIONS	ALL DIMENSIONS DISPLAYED ON THIS DRAWING ARE FOR REFERENCE ONLY	UNIT OF MEASUREMENT <b>MILLIMETER [ INCH ]</b>		IDENTIFICATION NO. U2-15644	
CONTACT TURCK FOR MORE INFORMATION		DO NOT SCALE THIS DRAWING		REV D	SHEET 1 OF 1

D	UPDATED CURRENT RATING	ER	04/26/19	69364
REV	DESCRIPTION	BY	DATE	ECO NO.